

VIRON® INTERNATIONAL CORP.

OWOSSO, MICHIGAN TEMPLE, TEXAS

989-723-8255

989-723-8417 FAX EMAIL: vironinfo@vironintl.com

ENVIRONMENTAL CONTROL SYSTEMS

USER		
REP.		
JOB NO.		
DATE	SHEET	OF
DRAWN BY		

STANDARD DIAMETERS

"A-B" = 4"-120"

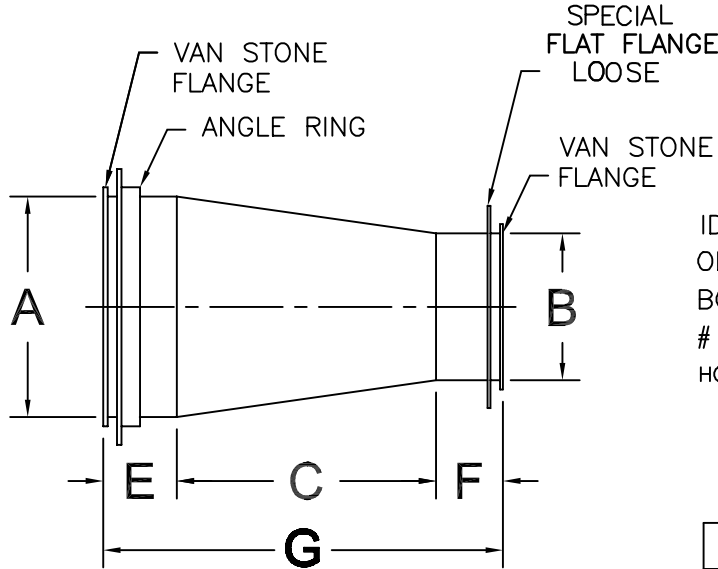

ID = _____
 OD = _____
 BC = _____
 # HOLES = _____
 HOLE SIZE = _____

STANDARD LENGTHS	
A-B	C
6" & UNDER	12"
8"	14"
10" TO 12"	24"
14" TO 18"	30"

STATIC PRESSURE

-6"WG -10"WG

OTHER: _____

NOTES:

- 304L 316 L SST MATERIAL WITH 2B FINISH.
- 304 SST ANGLE RINGS DRILLED
- HALAR COATING, INTERIOR ONLY.
- TIG WELDS ONLY.
- FUSION WELDS ON ALL LONGITUDINAL SEAMS.
- E & F REQUIRE A 3" MIN. LENGTH.

PART NUMBER	DESCRIPTION						GA	QTY	REMARKS
	A	B	C	E	F	G			

SSTEELCOAT® REDUCER w/FLG.