

VIRON[®] INTERNATIONAL CORP.

OWOSSO, MICHIGAN TEMPLE, TEXAS

989-723-8255

989-723-8417 FAX

EMAIL: vironinfo@vironintl.com

ENVIRONMENTAL CONTROL SYSTEMS

USER	
REP.	
JOB NO.	
DATE	SHEET OF
DRAWN BY	

STANDARD DIAMETERS "A-B" = 4"-120"

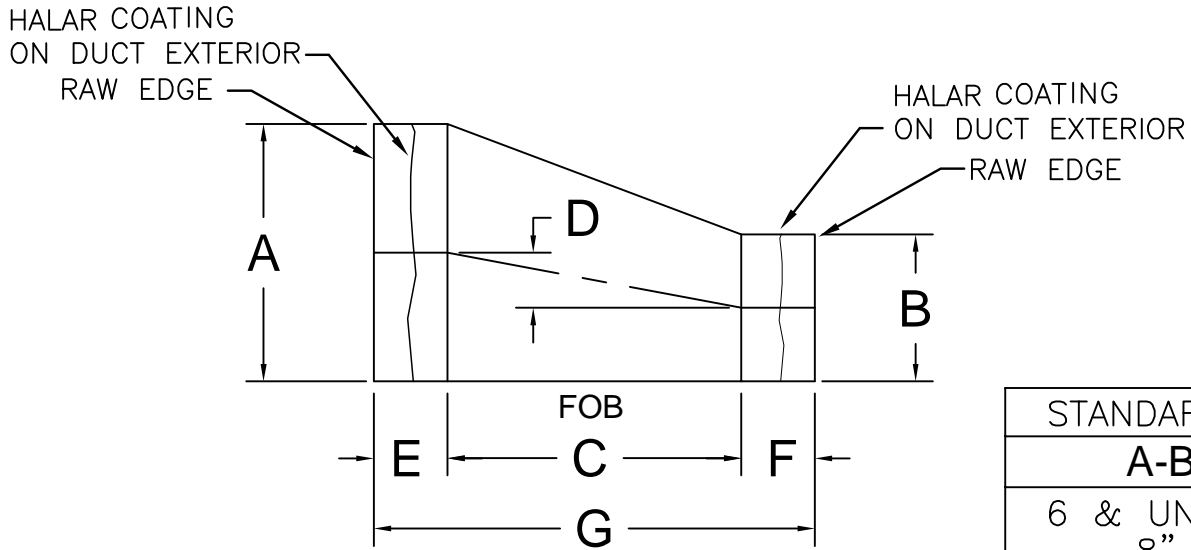

STANDARD LENGTHS	
A-B	C
6" & UNDER	12"
8"	14"
10" TO 12"	24"
14" TO 18"	30"

NOTES:

- 304L 316 L SST MATERIAL WITH 2B FINISH.
- 304 SST ANGLE RINGS DRILLED.
- HALAR COATING, INTERIOR ONLY.
- TIG WELDS ONLY.
- FUSION WELDS ON ALL LONGITUDINAL SEAMS.
- E & F REQUIRE A 3" MINIMUM LENGTH.

STATIC PRESSURE	
<input type="checkbox"/> -6" WG	<input type="checkbox"/> -10" WG
OTHER: _____	

PART NUMBER	DESCRIPTION							GA	QTY	REMARKS
	A	B	C	D	E	F	G			

SSTEELCOAT[®] REDUCER - FLAT ON BOTTOM