

**VIRON**® INTERNATIONAL CORP.

OWOSSO, MICHIGAN      TEMPLE, TEXAS

989-723-8255

989-723-8417 FAX      EMAIL: vironinfo@vironintl.com

ENVIRONMENTAL CONTROL SYSTEMS

USER		
REP.		
JOB NO.		
DATE	SHEET	OF
DRAWN BY		

**STANDARD DIAMETERS & LENGTHS**

"A" = 3"-24"

"B" = 12"

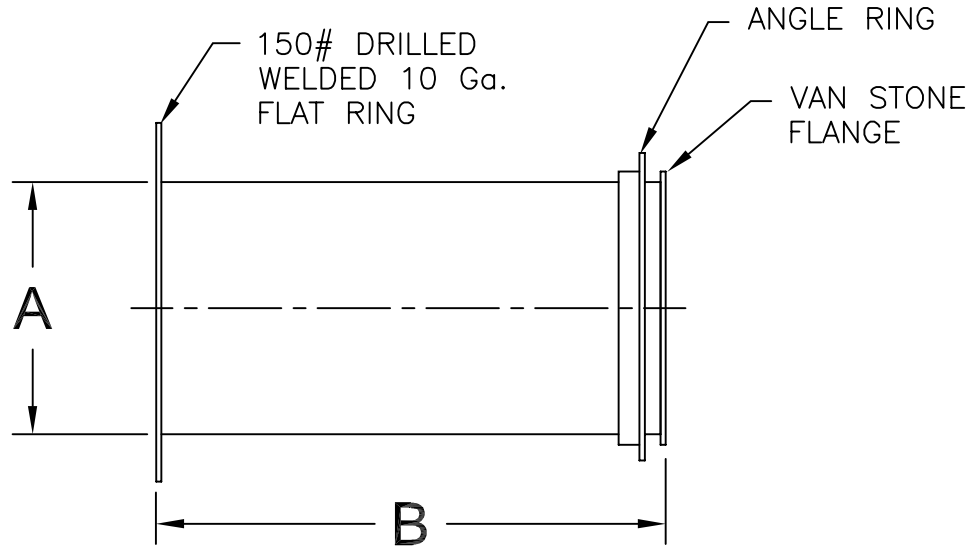

NOTES:

- 304L    316 L SST MATERIAL WITH 2B FINISH.
- 304 SST ANGLE RINGS DRILLED
- HALAR COATING, INTERIOR ONLY.
- FUSION WELDS ON ALL LONGITUDINAL SEAMS.
- ALL ANGLE RINGS OVER 30" DIA. WILL BE STITCHED WELDED.

STATIC PRESSURE

-6"WG    -10"WG

OTHER: \_\_\_\_\_

PART NUMBER	DESCRIPTION		GA	QTY	REMARKS
	A	B			

**SSTEELCOAT**® STRAIGHT WITH 150# FLANGE & ANGLE RING