

VIRON[®] INTERNATIONAL CORP.

OWOSSO, MICHIGAN TEMPLE, TEXAS
989-723-8255

989-723-8417 FAX EMAIL: vironinfo@vironintl.com

ENVIRONMENTAL CONTROL SYSTEMS

USER	
REP.	
JOB NO.	
DATE	SHEET OF
DRAWN BY	

STANDARD DIAMETERS & LENGTHS

- 4"Ø = 48" LONG
- 6"Ø - 16"Ø = 47¼" LONG
- 18"Ø - 120"Ø = 47" LONG

PLAN VIEW

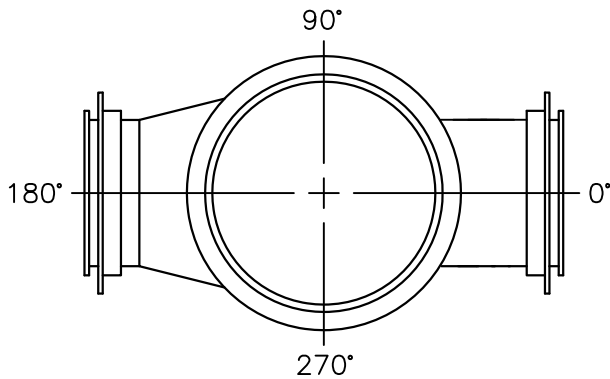
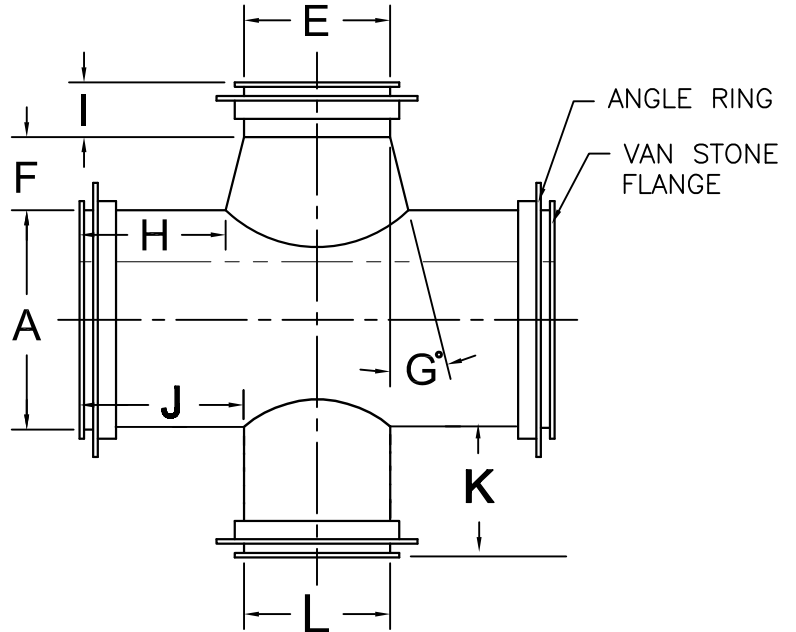

END VIEW

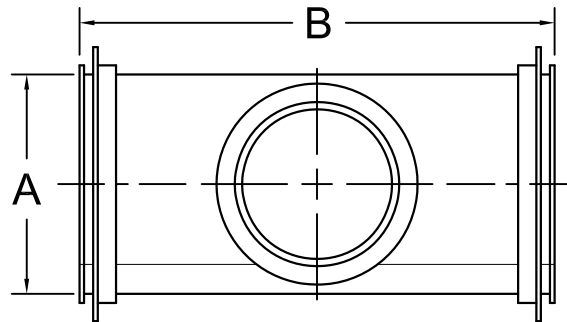

ELEVATION VIEW

NOTES:

1. 304L 316 L SST MATERIAL WITH 2B FINISH.
2. 304 SST ANGLE RINGS DRILLED
3. HALAR COATING, INTERIOR ONLY.
4. TIG WELDS ONLY.
5. FUSION WELDS ON ALL LONGITUDINAL SEAMS.
6. H REQUIRES A MINIMUM LENGTH OF 3".

STATIC PRESSURE

- 6"WG -10"WG

OTHER: _____

PART NUMBER	DESCRIPTION											GA	QTY
	A	B	E	F	G°	H	I	J	K	L			

SSTEELCOAT[®] TEE