

VIRON[®] INTERNATIONAL CORP.

OWOSSO, MICHIGAN TEMPLE, TEXAS
 989-723-8255 EMAIL: vironinfo@vironintl.com
 989-723-8417 FAX
 ENVIRONMENTAL CONTROL SYSTEMS

USER	
REP.	
JOB NO.	
DATE	SHEET OF
DRAWN BY	

STANDARD DIAMETERS
"A" = 4"-120"

REDUCING ELBOW

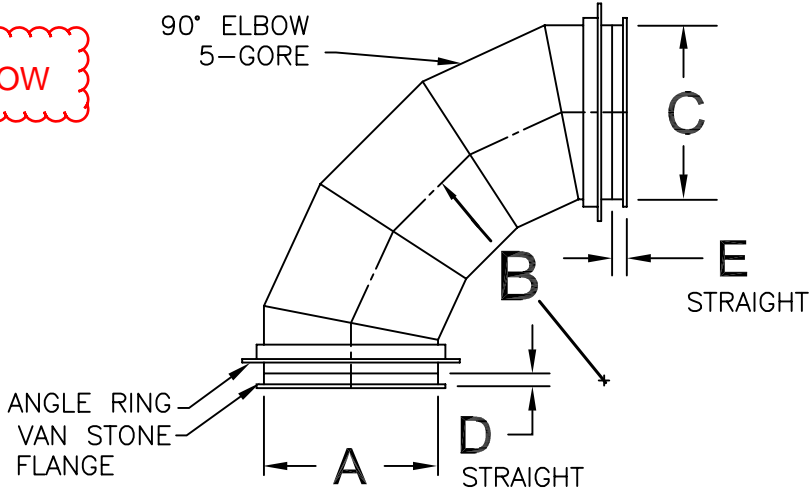

- NOTES:
- 304L 316 L SST MATERIAL WITH 2B FINISH.
 - 304 SST ANGLE RINGS DRILLED
 - HALAR COATING, INTERIOR ONLY.
 - TIG WELDS ONLY.
 - FUSION WELDS ON ALL LONGITUDINAL SEAMS.
 - STANDARD ELBOWS A=B.
 - THE END GORE MUST BE 3" MIN. LENGTH ON THE SHORT SIDE.
 - ALL 90° ELBOWS LARGER THAN 54" DIA. WILL BE MANUFACTURED IN TWO (2) PIECES.

STATIC PRESSURE

-6"WG -10"WG

OTHER: _____

PART NUMBER	DESCRIPTION					GA	QTY	REMARKS
	A	B	C	D	E			

SSTEELCOAT REDUCING ELBOW - 90° (5 gore)