

VIRON® INTERNATIONAL CORP.

OWOSSO, MICHIGAN TEMPLE, TEXAS

989-723-8255

989-723-8417 FAX EMAIL: vironinfo@vironintl.com

ENVIRONMENTAL CONTROL SYSTEMS

USER	
REP.	
JOB NO.	
DATE	SHEET OF
DRAWN BY	

STANDARD DIAMETERS

"A" = 4"-120"

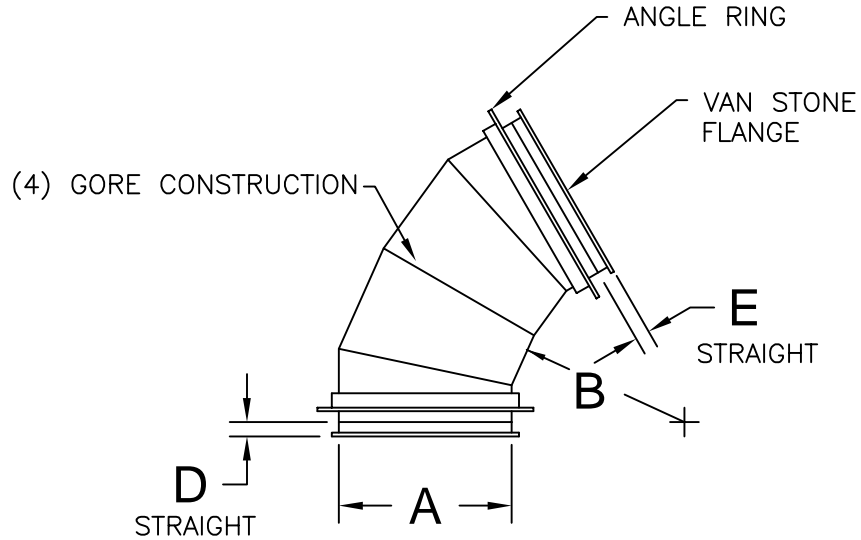

NOTES:

1. 304L 316L SST MATERIAL WITH 2B FINISH.
2. 304 SST ANGLE RINGS DRILLED
3. HALAR COATING, INTERIOR ONLY.
4. TIG WELDS ONLY.
5. FUSION WELDS ON ALL LONGITUDINAL SEAMS.
6. STANDARD ELBOWS B=A.

STATIC PRESSURE

-6"WG -10"WG

OTHER: _____

PART NUMBER	DESCRIPTION				GA	QTY	REMARKS
	A	B	D	E			

SSTEELCOAT® 60° ELBOW - 4 GORE