

VIRON[®] INTERNATIONAL CORP.

OWOSSO, MICHIGAN TEMPLE, TEXAS

989-723-8255

989-723-8417 FAX EMAIL: vironinfo@vironintl.com

ENVIRONMENTAL CONTROL SYSTEMS

USER		
REP.		
JOB NO.		
DATE	SHEET	OF
DRAWN BY		

STANDARD DIAMETERS & LENGTHS

4"Ø = 48" LONG

6"Ø - 16"Ø = 47¼" LONG

18"Ø - 120"Ø = 47" LONG

PLAN VIEW

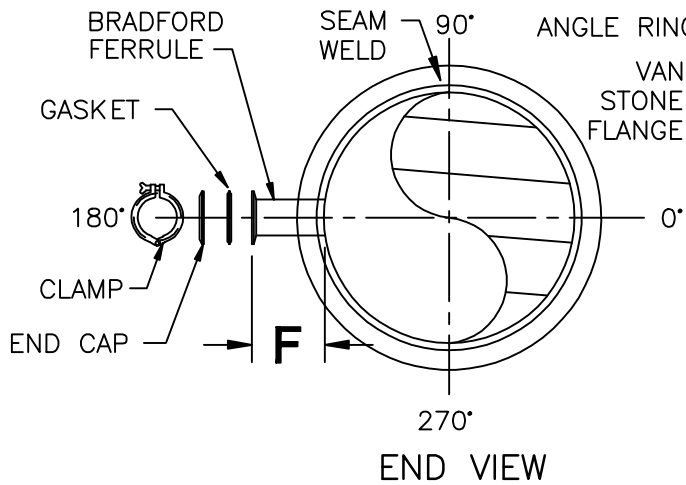
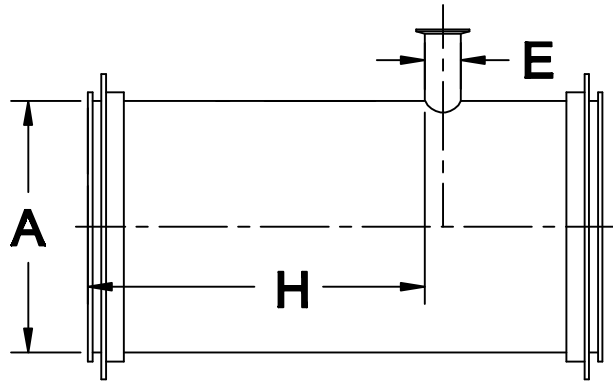

END VIEW

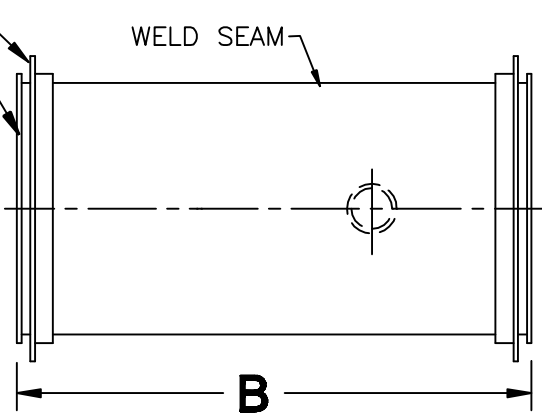

ELEV. VIEW

NOTES:

- 304L 316L SST MATERIAL WITH 2B FINISH.
- 304 SST ANGLE RINGS DRILLED.
- HALAR COATING, INTERIOR ONLY.
- TIG WELDS ONLY.
- FUSION WELDS ON ALL LONGITUDINAL SEAMS.

STATIC PRESSURE

-6"WG -10"WG

OTHER: _____

PART NUMBER	DESCRIPTION						GA	QTY	REMARKS
	A	B	E	F	H				

SSTEELCOAT[®] STRAIGHT w/ BRADFORD FERRULE ASSY