

VIRON[®] INTERNATIONAL CORP.

OWOSSO, MICHIGAN TEMPLE, TEXAS
 989-723-8255
 989-723-8417 FAX EMAIL: vironinfo@vironintl.com
 ENVIRONMENTAL CONTROL SYSTEMS

USER	
REP.	
JOB NO.	
DATE	SHEET OF
DRAWN BY	

STANDARD DIAMETERS & LENGTHS

- 4"Ø = 48" LONG
- 6"Ø - 16"Ø = 47¼" LONG
- 18"Ø - 120"Ø = 47" LONG

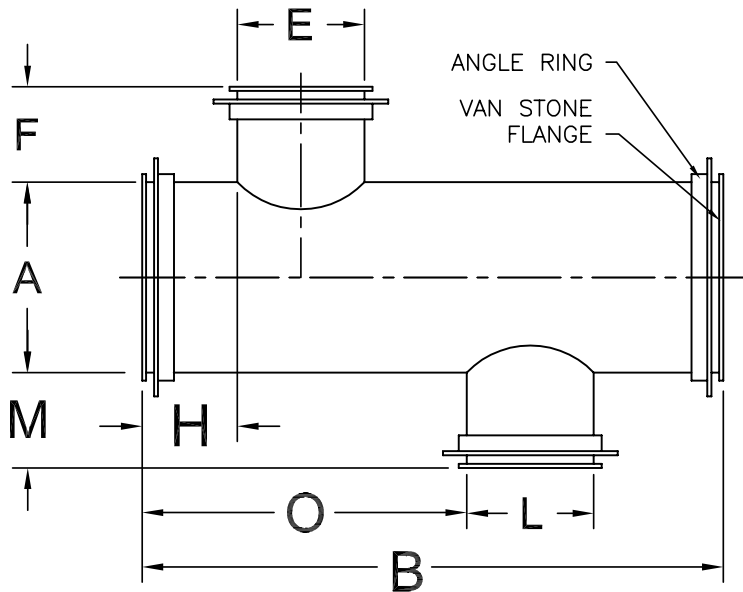
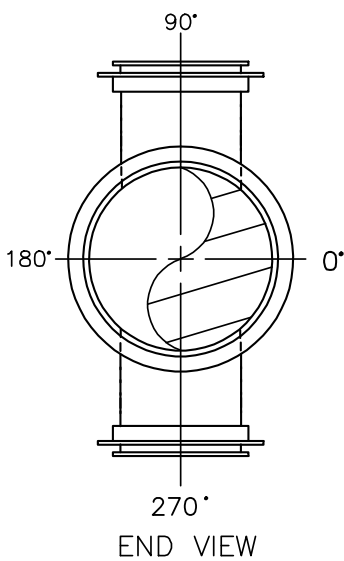

NOTES:

- 304L 316 L SST MATERIAL WITH 2B FINISH.
- 304 SST ANGLE RINGS DRILLED
- HALAR COATING, INTERIOR ONLY.
- TIG WELDS ONLY.
- FUSION WELDS ON ALL LONGITUDINAL SEAMS.
- H REQUIRES A MINIMUM LENGTH OF 3".

STATIC PRESSURE

-6"WG -10"WG

OTHER: _____

PART NUMBER	DESCRIPTION							GA	QTY	REMARKS
	A	B	E	F	H	L				

SSTEELCOAT[®] DUCT w/(2) STUB FLANGES