

VIRON[®] INTERNATIONAL CORP.

OWOSSO, MICHIGAN TEMPLE, TEXAS
 989-723-8255
 989-723-8417 FAX EMAIL: vironinfo@vironintl.com
 ENVIRONMENTAL CONTROL SYSTEMS

USER	
REP.	
JOB NO.	
DATE	SHEET OF
DRAWN BY	

STANDARD DIAMETERS "A" = 4"-120"

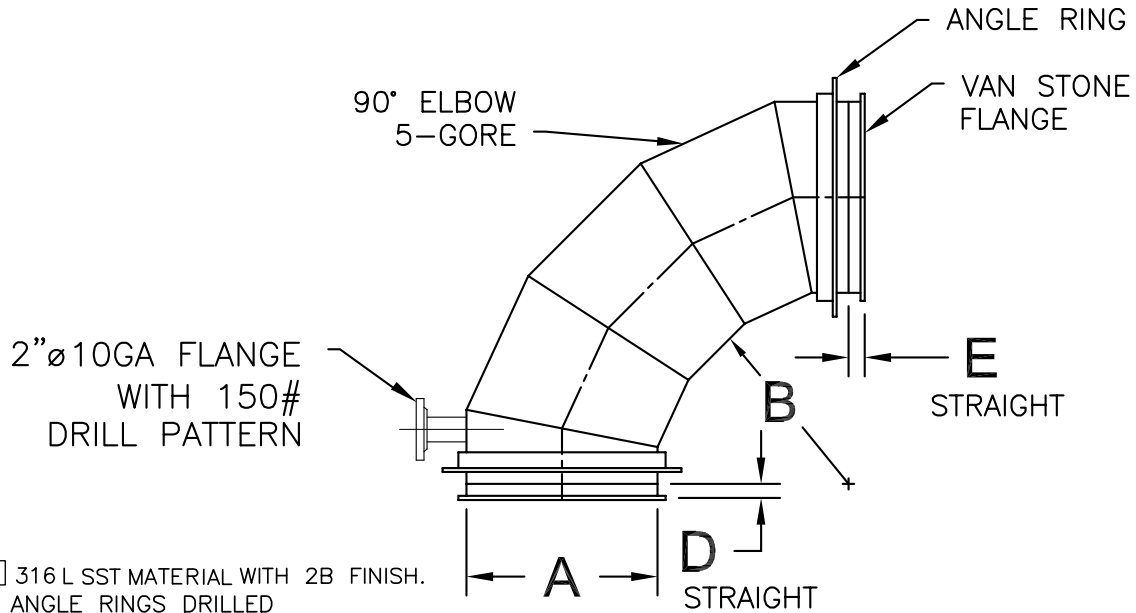

NOTES:

- 304L 316 L SST MATERIAL WITH 2B FINISH.
- 304 SST ANGLE RINGS DRILLED
- HALAR COATING, INTERIOR ONLY.
- TIG WELDS ONLY.
- FUSION WELDS ON ALL LONGITUDINAL SEAMS.
- STANDARD ELBOWS A=B.
- THE END GORE MUST BE 3" MIN. LENGTH ON THE SHORT SIDE.
- ALL 90° ELBOWS LARGER THAN 54" DIA. WILL BE MANUFACTURED IN TWO (2) PIECES.

STATIC PRESSURE

-6"WG -10"WG

OTHER: _____

PART NUMBER	DESCRIPTION				GA	QTY	REMARKS
	A	B	D	E			

SSTEELCOAT[®] 90° ELBOW -(5 GORE) W/DRAIN