

**VIRON**® INTERNATIONAL CORP.

OWOSSO, MICHIGAN      TEMPLE, TEXAS  
 989-723-8255  
 989-723-8417 FAX      EMAIL: vironinfo@vironintl.com  
**ENVIRON**MENTAL CONTROL SYSTEMS

USER		
REP.		
JOB NO.		
DATE	SHEET	OF
DRAWN BY		

**STANDARD DIAMETERS & LENGTHS**

- 4"Ø = 48" LONG
- 6"Ø - 16"Ø = 47¼" LONG
- 18"Ø - 120"Ø = 47" LONG

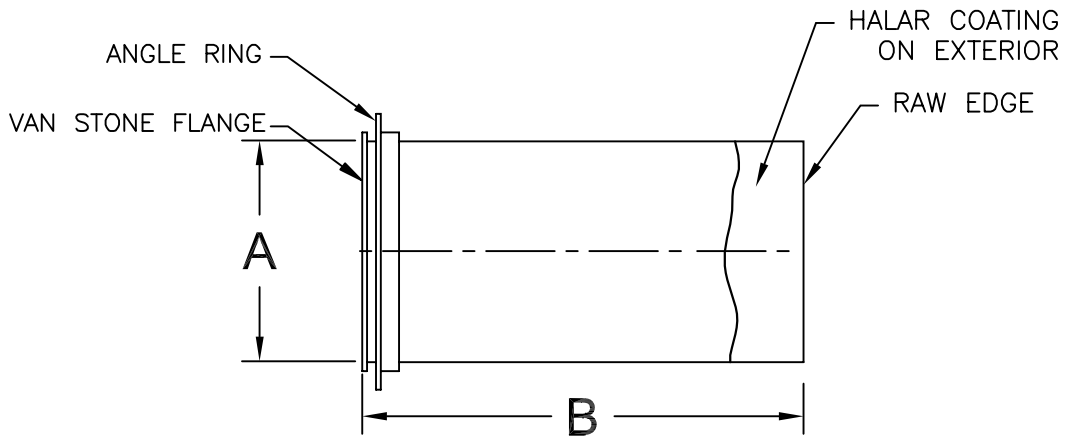

- NOTES:
- 304L  316L SST MATERIAL WITH 2B FINISH.
  - 304 SST ANGLE RINGS DRILLED.
  - HALAR COATING, INTERIOR ONLY.
  - FUSION WELDS ON ALL LONGITUDINAL SEAMS.
  - ALL ANGLE RINGS OVER 30" DIA. WILL BE STITCHED WELDED.

STATIC PRESSURE

-6"WG     -10"WG

OTHER: \_\_\_\_\_

PART NUMBER	DESCRIPTION		GA	QTY	REMARKS
	A	B			

**SSTEELCOAT**® STRAIGHT w/RAW EDGE