

VIRON[®] INTERNATIONAL CORP.

OWOSSO, MICHIGAN TEMPLE, TEXAS
 989-723-8255
 989-723-8417 FAX EMAIL: vironinfo@vironintl.com
 ENVIRONMENTAL CONTROL SYSTEMS

USER	
REP.	
JOB NO.	
DATE	SHEET OF
DRAWN BY	

STANDARD DIAMETERS & LENGTHS

- 4"ø = 48" LONG
- 6"ø - 16"ø = 47¼" LONG
- 18"ø - 120"ø = 47" LONG

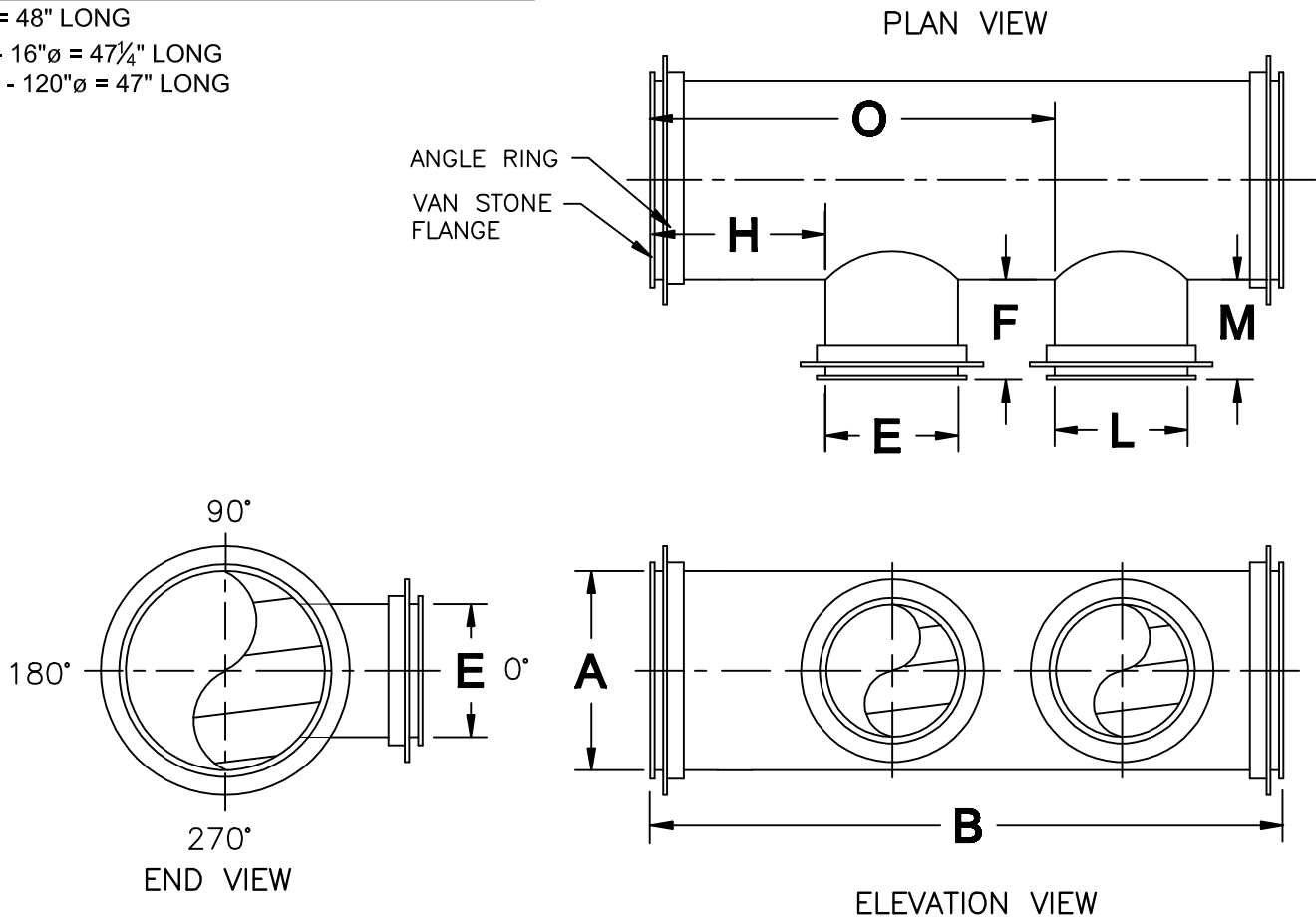

NOTES:

1. 304L 316 L SST MATERIAL WITH 2B FINISH.
2. 304 SST ANGLE RINGS DRILLED.
3. HALAR COATING, INTERIOR ONLY.
4. TIG WELDS ONLY.
5. FUSION WELDS ON ALL LONGITUDINAL SEAMS.
6. "F" REQUIRES A 6" MINIMUM LENGTH.
7. "H" REQUIRES A MINIMUM LENGTH OF 4".

STATIC PRESSURE

-6"WG -10"WG

OTHER: _____

PART NUMBER	DESCRIPTION								GA	QTY
	A	B	E	F	H	L	M	O		
REMARKS										

SSTEELCOAT[®] STR. w/(2) STUB FLANGES